

User Manual

Bijou²¹⁰⁰

High power 2.1 Amplifier and Preprocessor with eARC Input



Bijou³¹⁰⁰

High power 3.1 Amplifier and Preprocessor with eARC Input



Table of Contents

Introduction.....	3
Features	3
What’s in the Box.....	3
Specifications 2100	4
Specifications 3100	4
Front & Rear Panel Overview	
Bijou 2100 & 3100 Front Panel	5
Bijou 2100 & 3100 Rear Panel	5
Front Panel Details (2100,3100)	6
Rear Panel Details (2100,3100).....	7
Remote Control	9
Quick Start Guide.....	10
Installation.....	11
Web GUI	
Main.....	12
System Settings	13
Input Setup.....	15
Speaker Config.....	18
Graphic EQ.....	20
Network Settings	21
Firmware Update.....	22
Speaker Layouts.....	23
Internet Connectivity and Control	24
Troubleshooting.....	25
Command List.....	26
Related Products.....	31
Service.....	32
Warranty	33
Acknowledgements	34
Installation Notes.....	35

Introduction

Thank you and congratulations for the purchase of your AudioControl Bijou. Our first eARC enabled 3.1 amplifier with assignable preprocessed outputs, allowing for a full 5.1 surround sound environment.

Edge-of-the-art gallium nitride (GaN) amplifier technology enables Bijou series integrated amplifiers to reduce chassis size while vastly increasing Class-D audio fidelity. The ultra-compact Bijou series packs 48 years of AudioControl's USA engineering expertise into a 1 RU, half-rack-wide, thermally efficient, hardback spy novel-sized footprint. Speaking of novels, Bijou integrated amplifiers compose a new chapter in AudioControl Pro's book on leveraging GaN-semiconductors into high-current output circuit topologies, alongside our CM series Dual-Mode 70-volt designs and Hyperion Series RCV 11 AVR.

Features

- Best in class audio processing
- HDMI eARC input
- Digital Optical and Coax inputs
- Analog RCA Inputs
- Assignable RCA outputs
- Subwoofer output
- 3x 100W amplified outputs
- Dolby Atmos & DTS HD Surround Sound formats
- Full IP control integration
- Easy to navigate web interface

What's in the box

- The Bijou
- Bijou Remote
- AC Power cord
- 6-pin connector (attached to unit)
- Rack mounts
- A feeling of excitement

Specifications - 2100

Inputs

eArc Inputs	1 HDMI Audio-Only Input
Digital Inputs	1 Optical TOSLINK and 1 Coax S/PDIF
Analog Inputs	Stereo L/R RCA single-ended
Analog Input Impedance	47 k Ω
Analog Input Sensitivity	2 Vrms

Outputs

Preamp Outputs	Stereo L/R RCA single-ended
Subwoofer Output	1 RCA single-ended
Loudspeaker Level Outputs	2 via Euroblock connector
Power Output	100 W into 8 Ω , 200 W into 4 Ω

Audio

Minimum Speaker Load	4 Ω
Frequency Range	20 Hz to 20 kHz
Total Harmonic Distortion	0.15%
DAC	Capable of handling sampling rates up to 384 kHz and bit depths up to 32-bit

Power

Input Voltage	110 VAC to 240 VAC
Power Consumption	
Standby	3 W
Typical loud listening (1/8th power)	125 W
Maximum	700 W
BTU/hr	
Standby	10 BTU/hr
Typical loud listening (1/8th power)	340 BTU/hr
Maximum	2046 BTU/hr

Network

Default IP Address	192.168.1.249
--------------------	---------------

Dimensions

Height	1.7 in (43.9 mm)
Width	8.3 in (211.3 mm)
Depth	11.9 in (302.2 mm)
Weight	6 lbs. (2.7 kg)
Rack Space	1 RU High, half-rack width
Coffee of the Day	Mocha, with a hint of Rose

Specifications - 3100

Inputs	
eArc Inputs	1 HDMI Audio-Only Input
Digital Inputs	1 Optical TOSLINK and 1 Coax S/PDIF
Analog Inputs	Stereo L/R RCA single-ended
Analog Input Impedance	47 k Ω
Analog Input Sensitivity	2 Vrms
Outputs	
Preamp Outputs	Stereo L/R RCA single-ended
Subwoofer Output	1 RCA single-ended
Loudspeaker Level Outputs	3 via 6-pin Euroblock connector
Power Output	100 W into 8 Ω , 200 W into 4 Ω
Audio	
Minimum Speaker Load	4 Ω
Frequency Range	20 Hz to 20 kHz
Total Harmonic Distortion	0.15%
DAC	Capable of handling sampling rates up to 384 kHz and bit depths up to 32-bit
Power	
Input Voltage	110 VAC to 240 VAC
Power Consumption	
Standby	3 W
Typical loud listening (1/8th power)	125 W
Maximum	700 W
BTU/hr	
Standby	10 BTU/hr
Typical loud listening (1/8th power)	340 BTU/hr
Maximum	2046 BTU/hr
Network	
Default IP Address	192.168.1.249
Dimensions	
Height	1.7 in (43.9 mm)
Width	8.3 in (211.3 mm)
Depth	11.9 in (302.2 mm)
Weight	6 lbs. (2.7 kg)
Rack Space	1 RU High, half-rack width
Coffee of the Day	Mocha, with a hint of Rose

Front and Rear Panel Overview

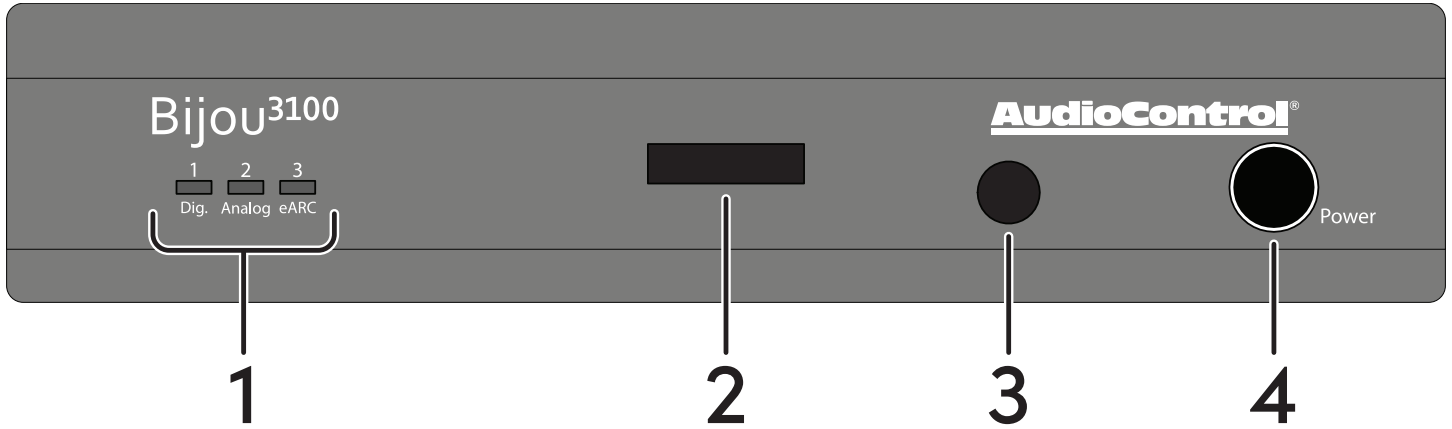

1. Input Selection LEDs
2. OLED Display Screen
3. IR Sensor
4. On/Standby Button

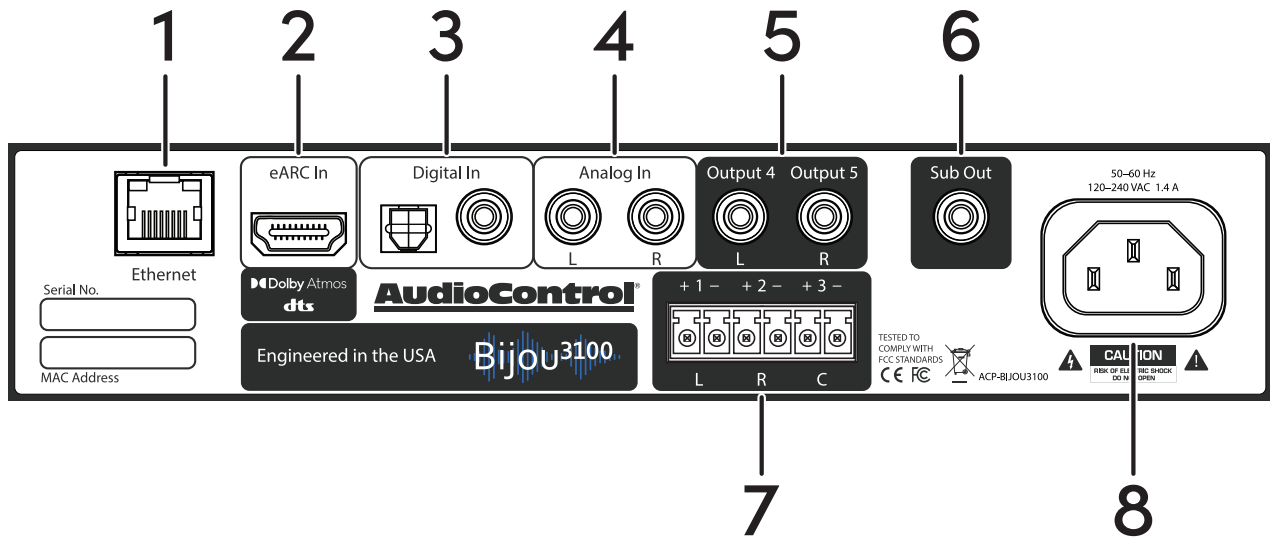

1. Ethernet Port
2. HDMI eARC Input
3. Optical TOSLINK and S/PDIF Digital Input
4. Analog RCA Input
5. Assignable Preamp Analog Output
6. Sub/LFE Output
7. Speaker Outputs
8. AC Input

Front Panel Details

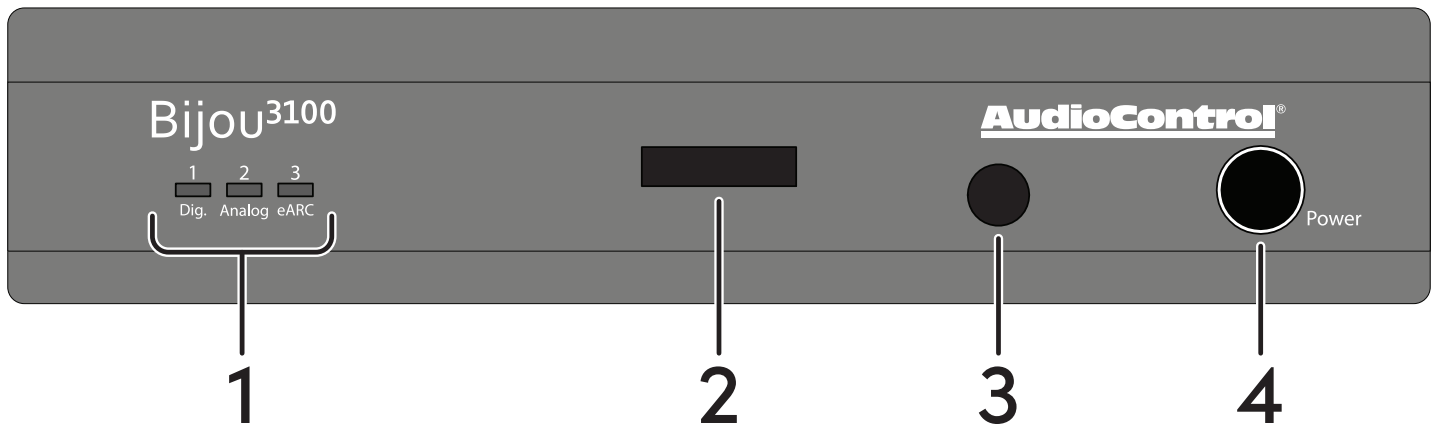

The front panels of the Bijou2100 and Bijou3100 are nearly identical, only the model number changes between them.

1. Input Selection LEDs

One of three blue LEDs will illuminate at a time to indicate which input is active.

2. OLED Display Screen

This screen displays helpful information like the IP address, audio mode, and volume level.

3. IR Sensor

This sensor receives the IR signals from the Bijou remote. Do not block this port, or else the remote control will not work. If the unit is hidden out of the line of sight, external IR equipment can be used, and an IR emitter may be placed over the sensor.

4. Power button

Press the button once to turn the unit on.

Hold down the button for 2 seconds to put the unit into standby.

Press and hold for 10 seconds to reset the unit to factory defaults.

The light around the power button will illuminate differently depending on the status of the amplifier.

Bright Blue	—	Normal Operation
Dim Blue	—	Standby Mode
Off	—	The unit is powered off
Beige	—	Smooth Jazz detected

Rear Panel Details

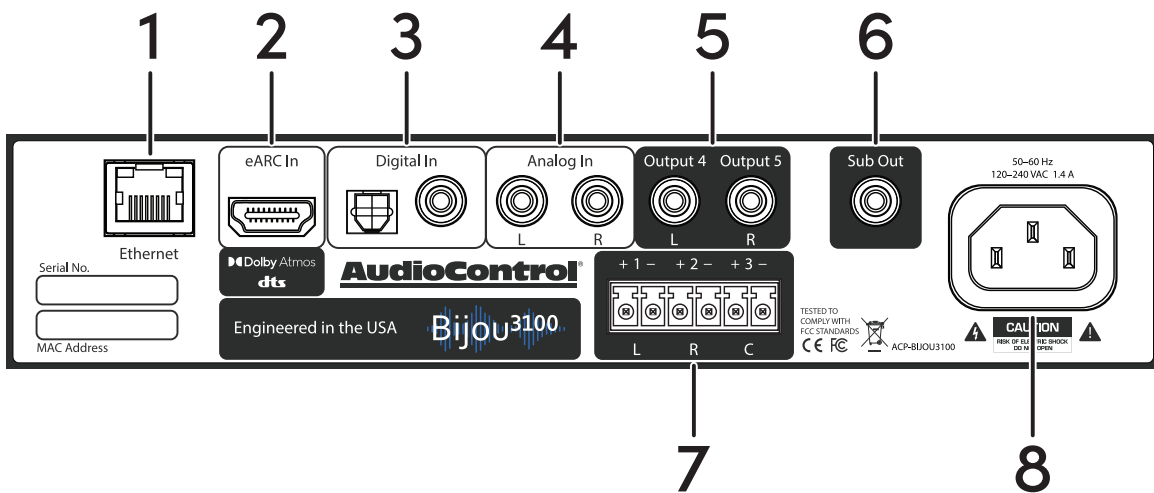
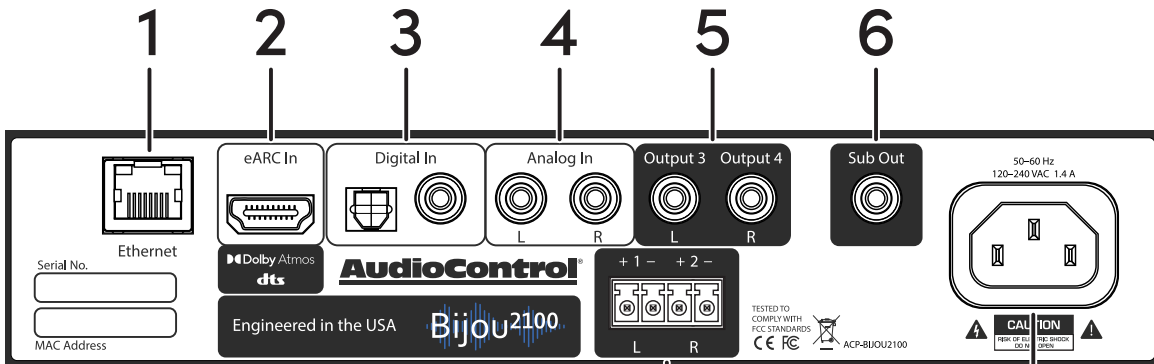

1. Ethernet Port

Connect a standard CAT 5 (or better) cable from the Ethernet port to a router or network switch to allow access to the Bijou web interface, and IP controls.

2. HDMI eARC Input

Connect a High Speed HDMI Cable with Ethernet (or better) from the eARC HDMI port on your TV to the eARC input on the Bijou to allow all TV audio to output from the Bijou. Adjust the TV's settings to make sure audio is sent via eARC.

Note: the eARC input does not send or receive video signals, and will not effect the video quality of your television.

3. Digital Inputs

The TOSLINK Optical and RCA S/PDIF coaxial digital inputs can receive multi-channel, bitsream, and PCM audio from a TV, streaming box, or other audio source.

Rear Panel Details

4. Analog RCA Input

These RCA line-level inputs accept the left and right analog signal from any source equipment, such as a CD player, DVD Player, or retro video game console

5. Assignable Preamp Analog Output

These RCA line-level outputs send audio signals to a secondary audio device. Depending on the settings, these can output front, surround, or height audio channels to a second amplifier, or provide a stereo downmix to headphones.

6. Sub/LFE Output

This RCA line-level output is used to send a mono output to a powered subwoofer or subwoofer amplifier. Using the Bijou settings, the low-pass frequency for the subwoofer can be adjusted to your preference.

7. Speaker Outputs

The speaker-level output of the amplifier connects from a Euroblock connector to your speakers or soundbar.

The Bijou2100 uses a 4-pin Euroblock connector for 2 amplified outputs, and the Bijou3100 uses a 6-pin Euroblock connector for its 3 amplified outputs.

Make a note of the polarity markings and make sure they match those of your speakers (positive to positive, negative to negative).

The left and right amplified outputs can be reassigned in the Bijou's Speaker Config menu.

8. AC Input

Connect the supplied AC power cord here, and plug the other end into a standard mains AC outlet. The Bijou can safely power on and operate with 110 V or 220 V AC power.

Disconnect power from the Bijou during lightning storms, when you are not using it for long periods of time (due to zombie apocalypses or tropical vacations), or if you are adjusting the connections of the amplifier.

Remote Control

1. **Power On/Standby**
Turn the unit On or put it into Standby.
2. **Mute/Unmute**
Mute or Unmute the audio.
3. **Volume Up/Down**
Adjust the volume from 0 to 100.
4. **Headphone Volume Up/Down**
If headphone mode is enabled, adjust headphone volume from 0 to 100.
5. **Mode**
The mode button lets you toggle between the audio modes of the Bijou.
6. **Input Selection**
Select between the eARC, Digital (D), or Analog (A) inputs.
7. **Info**
Displays helpful information on the front panel of the Bijou, like the IP address, current volume level, and decode mode.

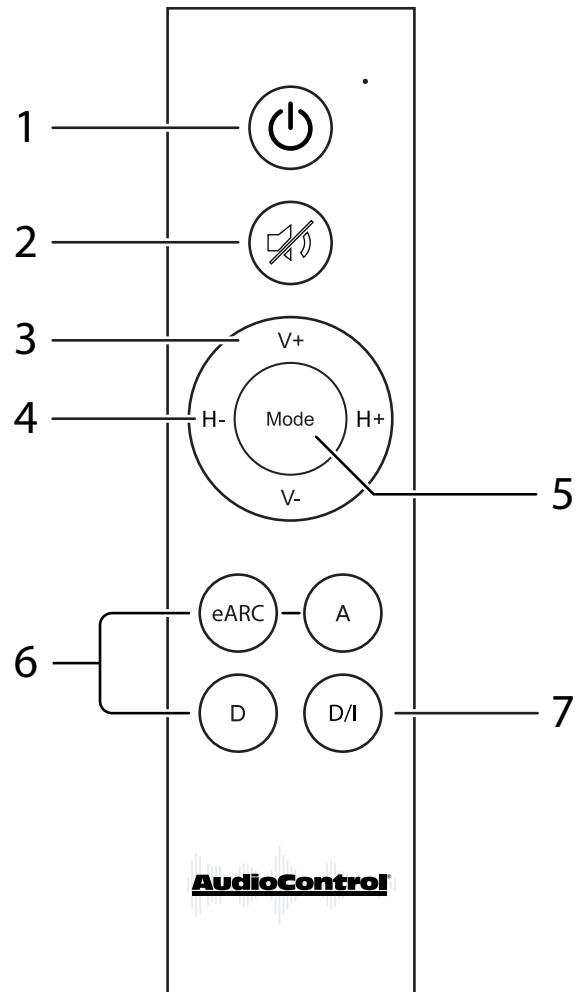

Quick Start Guide

In just a few short minutes after reading this page, your Bijou will be up and running. The steps below are explained in more detail throughout this manual.

1. Connect at least one source (i.e. a TV's eARC output, digital output of a PlayStation, digital music player, RCA output of a turntable, blender, etc.), to one of the inputs on the Bijou.
2. Connect an Ethernet cable from the local network to the Bijou's Ethernet port.
3. Connect your speakers or soundbar to the Speaker Outputs of the Bijou.
4. Connect the Bijou to power.
5. Using the Bijou remote or the button on the front panel, turn the Bijou on.
6. Using the Bijou remote, select the input you have connected to the Bijou.
7. Using the Bijou remote, adjust the volume to your preferred listening level.
8. Enjoy the great sound from the Bijou and have a mini dance party.

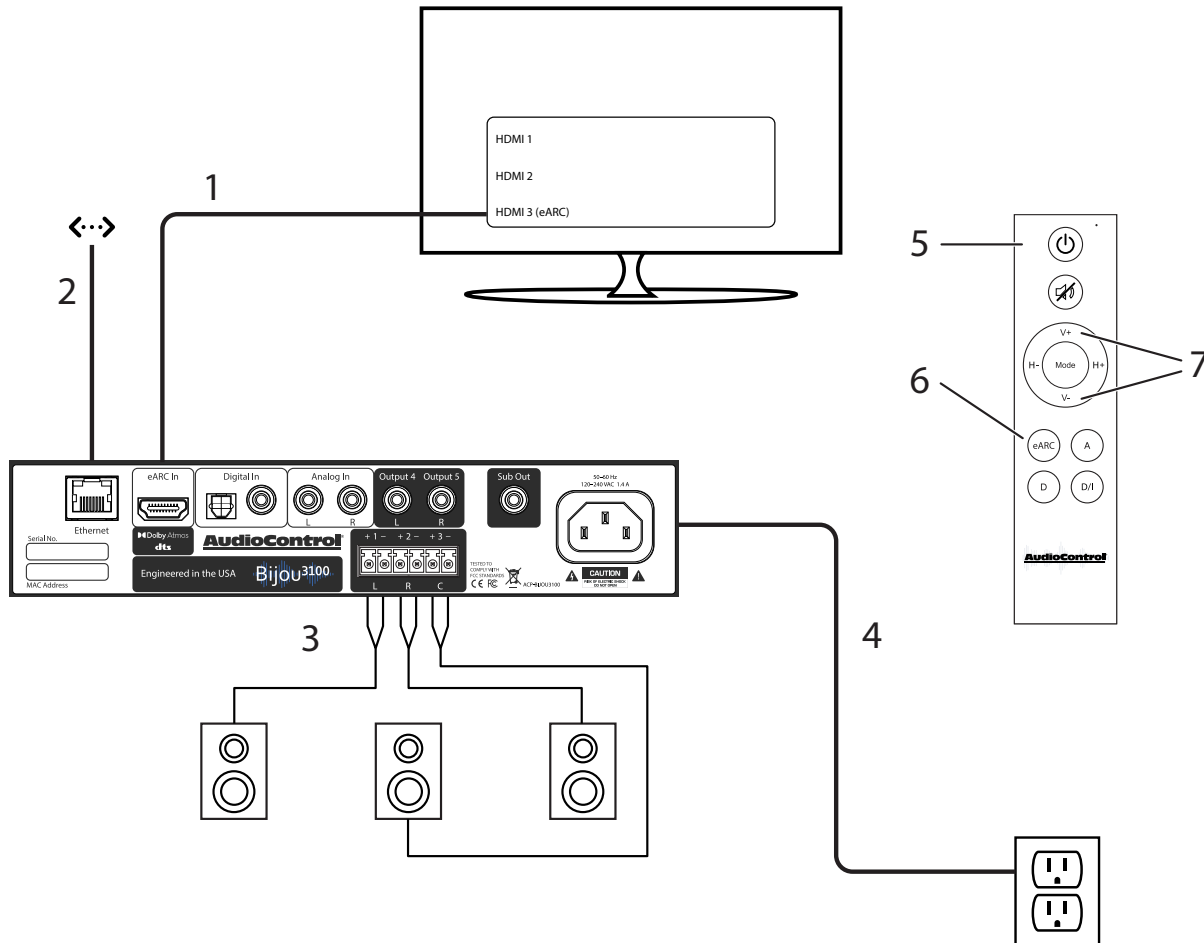

Installation

Now that we know what it looks like and how to power it on, it's time to decide where and how to install the Bijou.

Important Safety Note: Remove power at all times while conducting removal or installation of the Bijou.

Media Center

The simplest way to install the Bijou is to place it on a shelf in a media center. The Bijou comes equipped with 4 rubber feet to keep it elevated and stable, allowing for airflow on all sides.

Do not place the Bijou directly on top of or underneath a game console, AV receiver, amplifier, cable box, or any other heat-producing product in your media center.

Amp Rack

The Bijou only takes up just half of a rack space. AudioControl offers a rack mounting kit lets you fit the Bijou into a 1U rack space, or to fit 2 Bijous on the same 1U rack space.

Attach the rack mounts per the instructions of the chosen kit. For optimal performance, the Bijou should have at least 1U of empty space above and below it. However, we know space is limited, so up to 4 units can be stacked together. Any more than that and a rack space above and below is required for adequate ventilation.

Behind a TV

With proper mounting equipment, the Bijou can be mounted behind a TV. Attach the Bijou to the mount per the instructions provided with the kit. Mount the Bijou so the bottom of the amplifier faces the TV and the top panel is faces away from it, and ensure there is room for ventilation on all sides of the amplifier.

In-Wall Mount

The Bijou may be mounted in an enclosed wall box, following the instructions provided with the kit. As with all previous installations, make sure there is adequate room for ventilation around the sides and top of the amplifier.

Mount Doom

One does not simply install the Bijou in Mordor.

Web GUI

Once the Bijou is connected to the local network via Ethernet, open your browser of choice and type the unit’s IP address into the URL address bar to access your Bijou’s web GUI. The IP address is displayed on the Bijou front panel when the unit powers on.

Main

The Main page acts similar to the remote control, with a few additional settings.

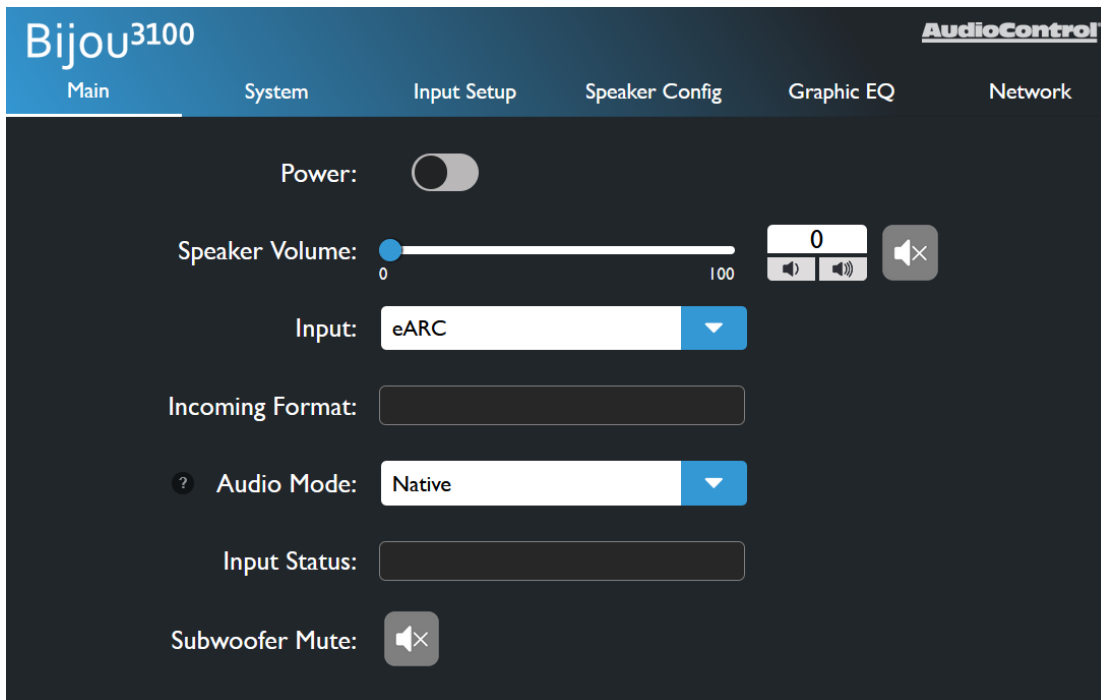

Power - Toggle the unit on or put it into standby.

Speaker Volume - Control the volume of the speaker outputs, or toggle the mute state of the speaker outputs.

Note: If Headphones are assigned to the line outputs and “Follow Speaker Volume” is enabled in System Settings, this slider will also control the headphone output.

Input - Select the input source.

Incoming Format - Displays information about the incoming audio signal.

Audio Mode - Sets the upmix mode for stereo signals, and sets the decode mode for multi-channel signals. This will automatically assign itself based on the incoming audio signal, but can be changed to stereo or multi-channel stereo.

Output Format - Displays the decode or upmix mode applied to the output.

Web GUI

Output - When headphones are connected, choose whether the audio outputs to speakers only, both speakers and headphones, or headphones only. This setting will be hidden if Headphones are not selected in the Speaker Config menu.

Headphone Volume - Control the volume of the speaker outputs, or toggle the mute state of the headphone output. This setting will be hidden if Headphones are not selected in the Speaker Config menu.

Note: This setting will be disabled if “Follow Speaker Volume” is enabled in the System Settings, or if Headphones are not selected in the Speaker Config Menu

Subwoofer Mute - Toggles mute on and off for the subwoofer output. This setting will not be available if no subwoofer is assigned in the Speaker Config menu.

System Settings

The settings on this page apply to the global functions of the Bijou.

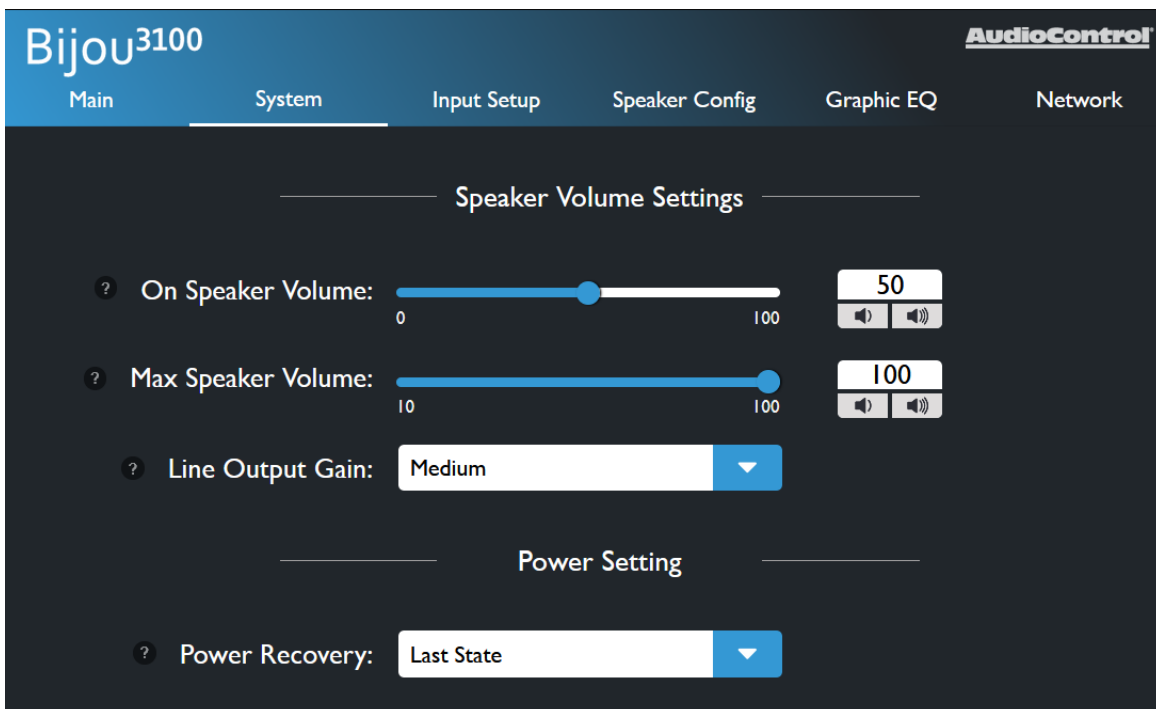

On Speaker Volume - Sets the default volume level for the Bijou. By setting this parameter, the Bijou will always return to this set value when powered on.

Max Speaker Volume - Sets a maximum limit on how high the user can increase the volume, helpful if you need to protect smaller speakers (or your ear drums).

Web GUI

Line Output Gain - Set the gain on the line outputs to Low, Medium (default), or High

On Headphone Volume - Sets the default volume level for the headphone output whenever the Bijou is powered on.

Max Headphone Volume - Sets a maximum limit on how high the user can increase the volume for the headphone output.

Follow Speaker Volume - Toggles volume control for the headphone output. When this setting is ON, the headphone volume level and mute state follow the main speaker volume and mute. When this setting is OFF, the headphone output will have independent volume and mute controls.

Note: Headphone volume settings are only available if the Line Outputs are set to Headphones in the Speaker Config menu. Otherwise, these settings are hidden.

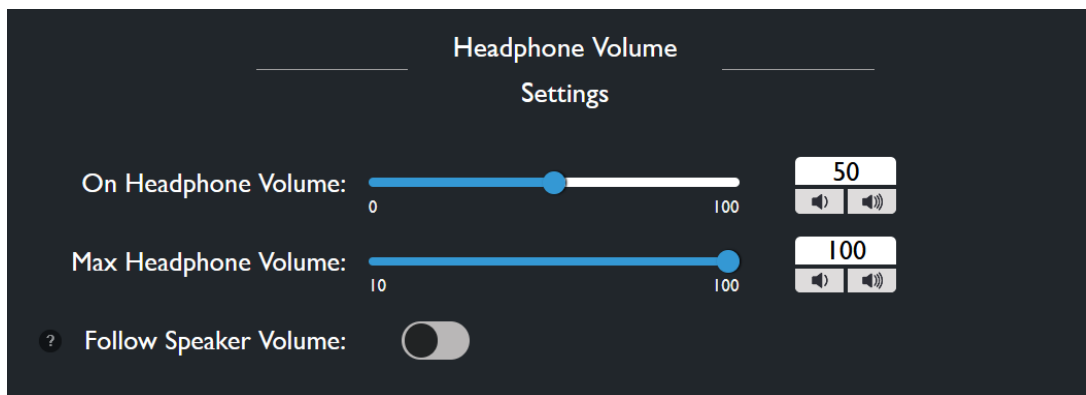

Power On - Determines the state the Bijou enters once power is restored after a loss of power.

- **Last State** - Enters whichever state it was in before losing power.
- **On** - Turns on once power is applied.
- **Off** - Stays in Standby once power is applied.

Serial Number - Displays this unit's serial number

MCU & DSP Firmware - Displays the Bijou's current firmware versions.

Update - Allows you to manually update the Bijou's firmware using a file saved locally on your computer.

System Reset - The Factory Reset button will restore the Bijou to its default settings. The reboot button will turn the Bijou off, and wake it back up.

Web GUI

Input Setup

In this menu, you can change settings that only affect specified inputs. Each of the settings

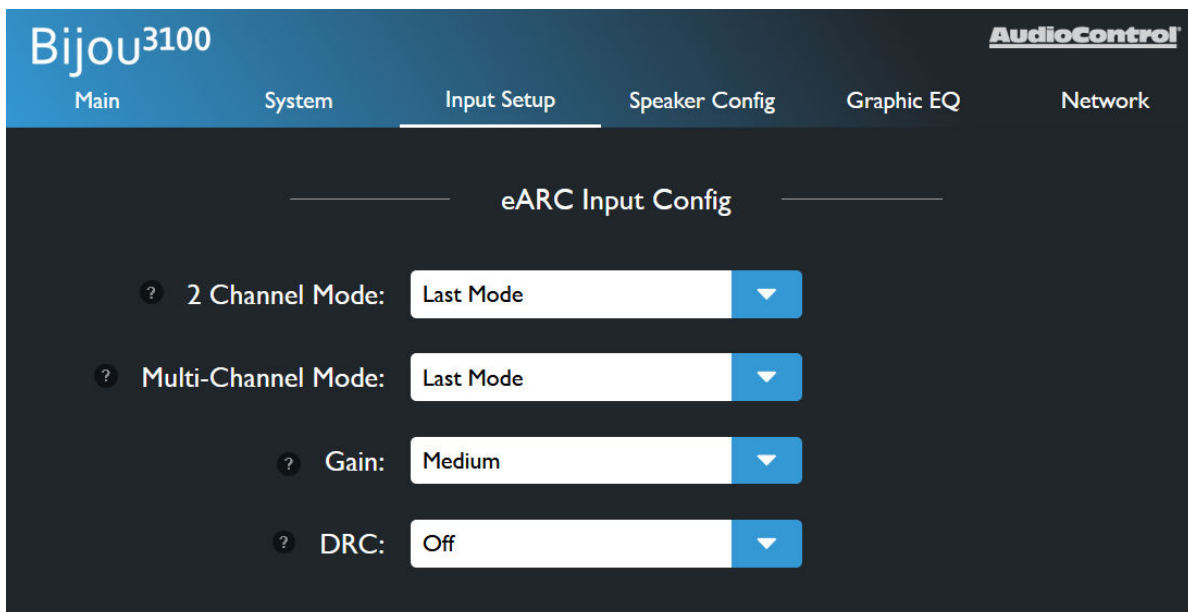

defined here are available on every input unless otherwise noted.

2-Channel Mode - Set the default upmix mode when the input receives a stereo signal.

Last Mode - Defaults to whichever setting was used the last time a stereo signal was received on this input.

2-Channel Stereo

All-Channel Stereo

Dolby Surround

Dolby Mode - Like Dolby Surround with the addition of Dolby's virtualization technology.

Multi-Channel Mode - Sets the default surround mode when the input receives a multi-channel signal.

Last Mode - Defaults to whichever setting was used the last time a multi-channel signal was received on this input.

Native - Leaves the incoming signal untouched, passing it through without alteration.

2-Channel Stereo

Web GUI

All-Channel Stereo

Dolby Surround

Dolby Mode - Like Dolby Surround with the addition of Dolby's virtualization technology.

The Multi-Channel Mode setting is not available for the Analog inputs.

Gain - For the eArc and Digital inputs, sets the reference level for these inputs. For the analog input, this sets the input sensitivity

Digital and eARC Input

- **Low** – 0 dB
- **Medium** – -6 dB
- **High** – -12 dB (we promise, this makes it louder)

Analog Input - the Gain sets the input sensitivity for the input:

- **Low** – 2 Vrms
- **Medium** – 1 Vrms
- **High** – 0.5 Vrms

Volume Defeat - Fixes the output level of the Bijou to maximum in order for the Bijou to accept a variable input. Allowing the source to control the volume, instead of the Bijou. This settings is not available on the eARC input.

Dynamic Range Control - Allows the user to ensure a consistent volume level when receiving either a Dolby or DTS encoded signal. This setting is only available on eARC and Digital inputs.

Signal Sense - Toggle this on to wake the unit from standby when signal is present on the selected input. This setting is not available on the eARC input.

Web GUI

Speaker Config

This menu allows you to configure the amplified and preamplified outputs on your Bijou.

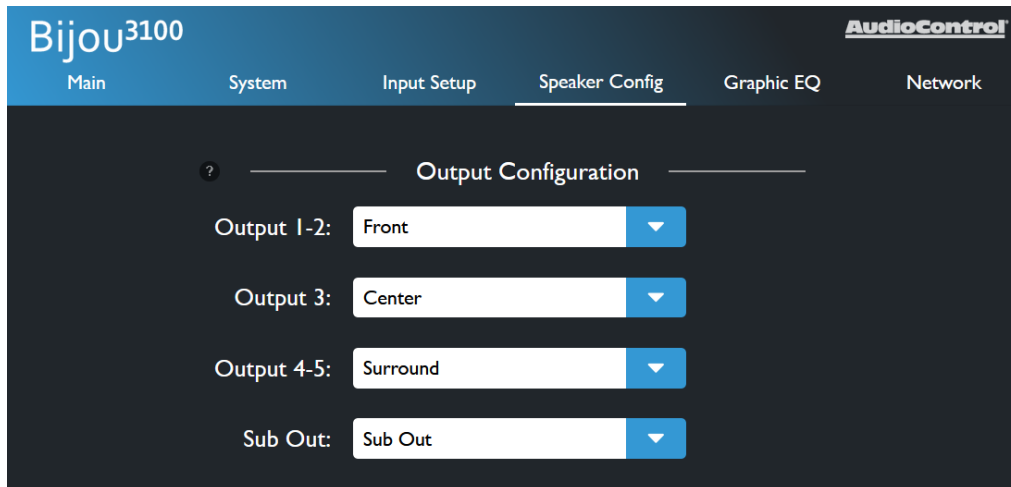

Output Configuration - Assign speaker channels each set of outputs, or turn the center and subwoofer channels on or off.

The Bijou2100 has 3 sets of outputs:

- Amplified outputs 1-2
- Line outputs 3-4
- Sub out

Both the amplified and line outputs can be assigned as either Fronts, Surrounds, or Heights. The line outputs may also be assigned as the Headphone output.

The Bijou 3100 has 4 sets of outputs:

- Amplified outputs 1-2
- Amplified output 3
- Line outputs 4-5
- Sub out

Outputs 1-2 and outputs 4-5 can be assigned as either Fronts, Surrounds or Heights. The line outputs may also be assigned as the Headphone output.

Output 3 is dedicated for the Center channel and can be turned off by setting this to "none."

Web GUI

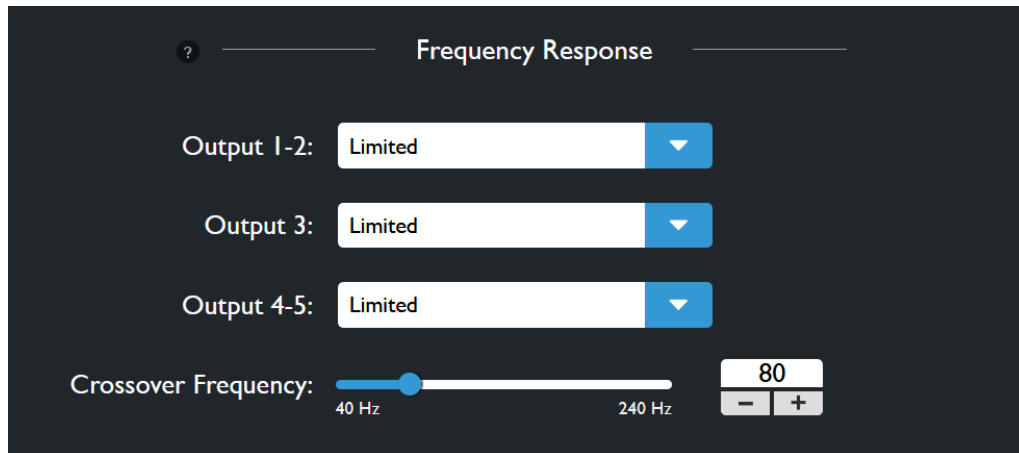

Frequency Response - Choose whether each set of outputs are full range or have a limited frequency response.

Full range - The output channel will pass all frequencies.

Limited - The output will have a high-pass crossover determined by the Crossover Frequency Slider.

Crossover Frequency - Sets the value of the low-pass filter for the subwoofer output and the high-pass filter for all speakers set to Limited. The crossover can be adjusted from 40 Hz to 240 Hz.

Output Gain - Adjust the gain for each output independently. The gain can be adjusted from -12 dB to +12 dB.

Test Tone - Select an output from the dropdown menu and press the play button (▶) to output pink noise to the selected output. Press the Pause Button (⏸) to stop the test tone.

Speaker Distances - Set the distance from selected channels to the listening position. You can set whether the measurement calculated in feet or meters. The distance can be adjusted from 0.1 ft (0.03 m) to 30 ft (9 m).

Web GUI

Graphic EQ

You may optionally set an EQ curve for each set of outputs on the Bijou.



EQ Enable - Toggle this ON to apply the EQ curve to the outputs, and turn it OFF to flatten the EQ curve back to default.

EQ Sliders - Each set of outputs has a 6-band EQ and 2 shelving filters for bass and treble.

Web GUI

Network Settings

Here you can set an automatic or static IP address for your Bijou. By default, the Bijou will automatically pick up an IP address if there is a DHCP server on the network.

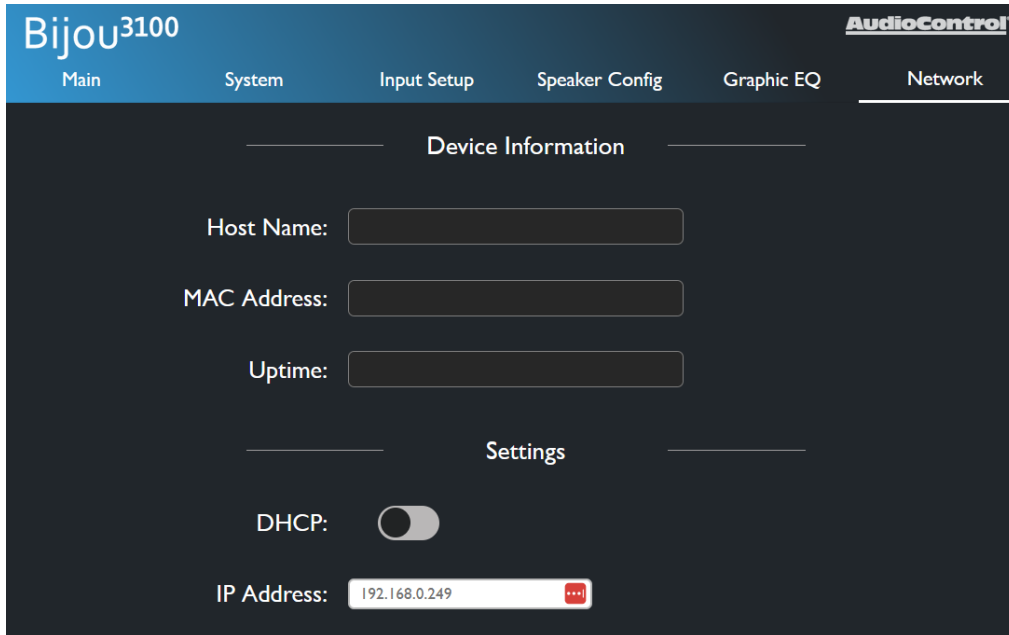

Device Information - This section tells you the unit’s Host Name, its MAC Address, and its Uptime (how long it has been powered on).

Settings - This section allows you to configure the IP settings for the Bijou.

DHCP - Set DHCP on or off. DHCP is enabled by default. To set a static IP address, turn DHCP off.

IP Address - Displays the current IP address for the Bijou. If you are setting a static IP address, you can type your desired address into this field. Double check all network devices to make sure a different device is not using your IP address.

When setting a static IP address, you will need to know the desired **Subnet Mask** and **Default Gateway**. If you do not know these, leave the unit set to DHCP and contact your network administrator.

Once your static IP settings are established, click the **Apply** button to save these settings.

TCP Port - Use this field to change the TCP port from its default to a port of your choosing. Click **Set TCP Port** to apply the change.

Firmware Update

Our dedicated team of engineers is always working to improve the quality of our products, and ensure it will last in your system for as long as possible. As such, firmware updates will be available occasionally when improvements are needed. It's always recommended to keep the firmware up to date, so be sure to check for updates regularly.

How To Update:

1. Download the latest firmware from your Bijou's product page on www.audiocontrolpro.com
2. Extract the files from the .zip folder
3. Open the Bijou's web interface by typing the unit's IP address or Host Name into your web browser of choice.
4. In the web interface, go to the **System Settings** menu, scroll down to **Firmware Update**, and click **Browse**.

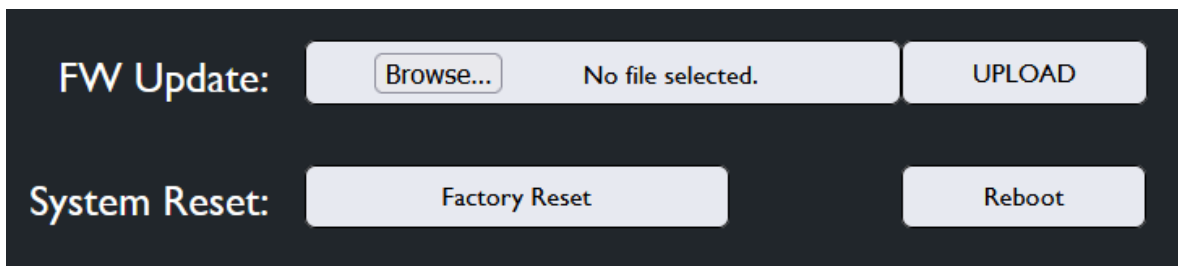

5. In the file browser window, navigate to and select the MCU firmware file you just downloaded.
6. Click **Upload** to begin the firmware update. This process may take a few minutes. When finished, the unit will reboot.
7. Refresh the page, return to the **System Settings** menu, scroll down to **Firmware Update**, and click **Browse**.
8. Now, navigate to and select the DSP firmware file, then click **Upload**.
9. The update may take up to 5-10 minutes.
10. When the update is finished the page will refresh, and the version number will be updated.

Speaker Layouts

Below is a guide detailing the different speaker layouts possibilities on the Bijou2100 and Bijou3100, and how certain audio formats will output audio with those layouts.

All listening modes are compatible with every speaker layout, but some speakers may be silent depending on the format. For example, in a 3.1.2 system, Dolby Digital (DD) content will play perfectly fine, but the two height channels will be silent because standard DD does not upmix to those speaker channels.

Speaker Layout → Listening Mode ↓	2.x	3.x	4.x	5.x	2.x.2	3.x.2
2-Channel Stereo	✓					
All-Channel Stereo	✓	✓	✓	✓	✓	✓
DD	✓	✓	✓	✓		
DD+	✓	✓	✓	✓	✓	✓
DTHD	✓	✓	✓	✓	✓	✓
Atmos	✓	✓	✓	✓	✓	✓
Dolby Surround	✓	✓	✓	✓	✓	✓
DTS	✓	✓	✓	✓		

Internet Connectivity and Control

Access the Bijou's web interface, connect the device's Ethernet port to a network switch or router using a CAT 5 or better cable.

If a DHCP is enabled on your network, the Bijou will display the IP address on the front panel display. If the display is off, press the power button to wake it up.

Open a web browser, enter the IP address, and the web interface will open!

Note: Some browsers don't like leading zeros in IP addresses. For example, if the IP Address reads as 010.000.000.089, remove any leading 0 and enter 10.0.0.89.

Connecting Without a Network

If DHCP isn't enabled on your network, or you'd like to setup the Bijou without connecting it to the local network, the Bijou can be connected directly to a computer by plugging a CAT 5 (or better) cable from the Bijou's Ethernet port to your computer's.

The Bijou's default IP address is: **192.168.1.249**

Set the computer's IP address to fit in the same subnet as the Bijou's default IP address: **192.168.1.x**, where x is any number between 2-255 **excluding 249**. Open your browser, enter the default IP address, and the web interface will open.

Changing the IP address on a Windows computer

On a Windows 11 PC, open the **Settings** app, select **Network & Internet**, then click **Ethernet**. On **IP Assignment**, click **Edit**, change from **Automatic** to **Manual**, turn on **IPv4**, and enter the information below.

On a Windows 10 or older PC, go to **Control Panel > Network and Internet > Network Connections**, right-click the **Ethernet**, and select **Properties**. Select **Internet Protocol Version 4**, and click the **Properties** button. Select **Use the following IP address** and enter the information below

IP Address: 192.168.1.23* **Subnet Mask:** 255.255.255.0

Gateway: 192.168.1.1 **DNS:** 8.8.8.8 (not needed on Windows 10 or older)

Then click **Save** (or **OK**).

*The IP address should be 192.168.1.x, where x is any number from 2-255 excluding 249.

Changing the IP address on an Apple computer

Differing versions of Apple hardware and operating systems may have different instructions. If in doubt, try searching for instructions online.

Open **System Preferences**, select **Network**, and under **Other Services** select the port on the computer connected to the Bijou. Click **Details**, select **TCP/IP**, set **Configure IPv4** to **Manually**. In the **IP address** field, type in 192.168.1.x, where x is any number from 2-255 excluding 249, then click **OK**.

Remember to revert network settings to "Automatic" or "Using DHCP" when finished setting up the Bijou.

Troubleshooting

There are no lights on the Bijou

- Pressing the power button on the front panel or the factory remote should wake the Bijou.
- Verify that the power cord is plugged into a live AC outlet.
- Verify that the power switch on the back of the unit is in the ON position.

The audio doesn't match the video

- Confirm that you are on the correct input.
- Switch to a different audio mode.

Audio sound is poor or distorted

- Verify speaker configuration settings matches your speakers.
- Verify that all interconnect cables are fully seated in their ports. Disconnect and reconnect them to ensure a good connection.
- You're listening to an old album by The Mountain Goats

Humming on the outputs

- Replace input cables and ensure they are connected properly.
- Disconnect all input cables. If the hum disappears, connect one input at a time until the hum returns. That input may have a bad connection, or may require a ground isolator.

No Audio from the TV

- Check your TV's sound settings to ensure that the eARC channel or Digital output is enabled.

The Bijou is not coming out of standby

- Remove power from the Bijou and disconnect all inputs and outputs. Let the amp sit without power for at least 5 minutes, then reconnect power.

The Bijou is not appearing on the network

- Connect the Bijou's ethernet port directly to a computer and try accessing the default IP address: 192.168.0.249
- If there was an issue setting up the static IP address, press and hold the Power button for 10 seconds to factory reset the Bijou.

My soufflé didn't rise

- Increase oven temperature.

Command List

Command	Description
H	Help
STA	Show system status
SET RBT	Reboot device
SET RST	Reset to factory defaults
GET STA	Get settings status
GET INPUT STATUS	Get input signal type information
GET SER NUM	Get current product serial number
GET MODEL	Get the unit model
GET MODELNAME	Get the unit model (alternative command)
GET VER INF	Get system firmware versions
SPEAKER VOLUME Commands	
SET VOL x	Set speaker volume level x {x=[0~100]}
SET VOL+ x	Increase speaker volume level by x {x=[1~100, optional default=1]}
SET VOL- x	Decrease speaker volume level by x {x=[1~100, optional default=1]}
SET MAX VOL x	Map the maximum speaker max volume level x to 100. {x=[10~100]}
SET POWER ON VOL x	Set the speaker volume level x when the unit powers on {x=[0~100]}
SET INPUT x	Set Audio Output to Input x{x=[EARC,DIGITAL,ANALOG]}
SET AUDIO MODE x	Set the active decoder mode x {x=[NATIVE, 2CHSTEREO, ALLCHSTEREO, DOLBY SURROUND]}
SET OUTPUT x	Set the enable state x for speaker and/or headphone outputs {x=[SPEAKER, HEADPHONE, BOTH]}
SET INPUT x	Set Audio Output to Input x{x=[EARC,DIGITAL,ANALOG]}
SET AUDIO MODE x	Set the active decoder mode x {x=[NATIVE, 2CHSTEREO, ALLCHSTEREO, DOLBY SURROUND]}
SET OUTPUT x	Set the enable state x for speaker and/or headphone outputs {x=[SPEAKER, HEADPHONE, BOTH]}
HEADPHONE VOLUME Commands	
SET HVOL x	Set headphone volume level x {x=[0~100]}
SET HVOL+ x	Increase headphone volume level by x {x=[1~100, optional default=1]}
SET HVOL- x	Decrease headphone volume level by x {x=[1~100, optional default=1]}

SET MAX HVOL x	Map the maximum headphone max volume level x to 100. {x=[10~100]}
SET POWER ON HVOL x	Set the headphone volume level x when the unit powers on {x=[0~100]}
SET HVOL FOLLOW x	Set headphone volume to follow speaker volume {x=[OFF,ON]}
SET HMUTE	Mute headphone output
SET HUNMUTE	Unmute headphone output
GET HVOL	Get speaker volume level
GET MAX HVOL	Get value of lineout max volume level {[10~100]}
GET POWER ON HVOL	Get the headphone volume level when the unit powers on {[0~100]}
GET HVOL FOLLOW	Get status of lineout volume follow mode {[OFF/ON]}
GET HMUTE	Get status of lineout mute {[MUTE/UNMUTE]}
INPUT Commands	
SET INPUT x	Set Audio Output to Input x{x=[EARC,DIGITAL,ANALOG]}
SET AUDIO MODE x	Set the active decoder mode x {x=[NATIVE, 2CHSTEREO, ALLCHSTEREO, DOLBY SURROUND]}
SET OUTPUT x	Set the enable state x for speaker and/or headphone outputs {x=[SPEAKER, HEADPHONE, BOTH]}
SET SOURCE AUDIO x y	Set input x fixed/variable audio y configuration {x=[DIGITAL, ANALOG], y=[FIXED, VARIABLE]}
SET 2CH MODE x y	Set input x default surround mode y when input is two-channel audio {x=[EARC, DIGITAL, ANALOG], y=[LAST, 2CHSTEREO,ALLCHSTEREO]}
SET MULTICH MODE x y	Set input x default surround mode y when input is multi-channel audio {x=[EARC, DIGITAL], y=[LAST,NATIVE,2CHSTEREO,ALLCHSTEREO, DOLBY SURROUND]}
SET LIPSYNC DELAY x y	Set Input x audio lip sync delay {x=[EARC, DIGITAL, ANALOG], y=[0-250]}
SET DRC x y	Set Dynamic Range Control mode to x {x=[EARC, DIGITAL], y=[OFF/ON/AUTO]}
GET INPUT	Get Audio Input
GET AUDIO MODE x	Set the active decoder mode x {x=[NATIVE, STEREO, MULTI]}
GET OUTPUT x	Get the enable state x for speaker and/or headphone outputs {x=[SPEAKER, HEADPHONE, BOTH]}
GET SOURCE AUDIO x y	Get input x fixed/variable audio y configuration {x=[DIGITAL, ANALOG], y=[FIXED, VARIABLE]}
GET MULT CH MODE x	Get the multichannel decode mode
GET TWO CH MODE x	Get the two channel decode mode

GET LIPSYNC DELAY x	Get Audio Input to x to matches the video from sources{x=[0-250]}
GET DRC MODE x	Get Dynamic Range Control mode
SUBWOOFER Commands	
SET SUB MUTE	Mute subwoofer output
SET SUB UNMUTE	Unmute subwoofer output
GET SUB MUTE	Get status of subwoofer mute {[MUTE/UNMUTE]}
Bijou 2100 SPEAKER CONFIG Commands	
SET TEST TONE OUT x	Sends a full-range pink noise signal to output x. {x=[1~4, SUB,NONE]}
SET OUT CH x y z	"Assign channel/channel pairs w,x,y and z to all output(s) 1_2, 3_4, and SUB {x=[FRONT, SUR, TM, FH, DE, NONE]; y=[FRONT, SUR, TM, FH, DE, HP, NONE]; z=[SUB, NONE]} SUR=SURROUND, TM=TOP MIDDLE, FH=FRONT HEIGHT, DE=DOLBY ENABLED, HP=HEADPHONE, SUB=SUBWOOFER 1_2=OUTPUT 1 (L) and OUTPUT 2 (R),3_4=OUTPUT 3 (L) and OUTPUT 4 (R) "
SET OUT CH GAIN x y	Set the gain in dB for the channel assigned to output x For Bijou2100: {x=[1~4, SUB,NONE]}, {y=[-12~12]} For Bijou3100: {x=[1~5, SUB,NONE]}, {y=[-12~12]}
SET OUT CH DISTANCE x y z	"Set the distance y (in units z) between the speaker assigned to output x and the listener. Limited to one x y z entry. For Bijou2100: {x=[1~4, SUB,NONE]}, For Bijou3100: {x=[1~5, SUB,NONE]}, {y=[0.1~30] 0.1 step, z=[FEET]; y=[0.03~9] 0.01 step, z=[METERS]}"
SET OUT FREQ RESPONSE x y	"Set output x frequency response y {x=[1&2, 3&4, ALL], y=[XOVER,FULLRANGE]} 1&2=OUTPUT 1 (L) and OUTPUT 2 (R), 3&4=OUTPUT 3 (L) and OUTPUT 4 (R)
SET XOVER FREQ x	Set cross over cutoff frequency y for channel(s) x in increments of 5 {x=[40~120]}
GET OUT CH	" Get channel/channel pairs assigned to output(s) 1_2, 3_4, SUB in order SUR=SURROUND, TM=TOP MIDDLE, FH=FRONT HEIGHT, DE=DOLBY ENABLED, HP=HEADPHONE, SUB=SUBWOOFER 1_2=OUTPUT 1 (L) and OUTPUT 2 (R), 3_4=OUTPUT 3 (L) and OUTPUT 4 (R) "
GET OUT CH GAIN x y	Get the gain in dB for the channel assigned to output x {x=[1~4, SUB, ALL], y=[-12~12]}

GET OUT CH DISTANCE x	" Get the distance with units between the speaker assigned to output x and the listener. {x=[1~4, SUB, ALL] } "
GET OUT FREQ RESPONSE x y	" Get output x frequency response y {x=[1&2, 3&4, ALL] } 1&2=OUTPUT 1 (L) and OUTPUT 2 (R), 3&4=OUTPUT 3 (L) and OUTPUT 4 (R) "
GET XOVER FREQ x	Get cross over cutoff frequency y for channel(s) x in increments of 5 {x=[40~120]}
Bijou3100 SPEAKER CONFIG Commands	
SET TEST TONE OUT x	Sends a full-range pink noise signal to output x. {x=[1~5, SUB,NONE]}
SET OUT CH w x y z	"Assign channel/channel pairs w,x,y and z to all output(s) 1_2, 3, 4_5, and SUB {w=[FRONT, SUR, TM, FH, DE, NONE]; x=[CENTER, NONE]; y=[FRONT, SUR, TM, FH, DE, HP, NONE]; z=[SUB, NONE]} SUR=SURROUND, TM=TOP MIDDLE, FH=FRONT HEIGHT, DE=DOLBY ENABLED, HP=HEADPHONE, SUB=SUBWOOFER 1_2=OUTPUT 1 (L) and OUTPUT 2 (R), 3=OUTPUT 3, 4_5=OUTPUT 4 (L) and OUTPUT 5 (R) "
SET OUT CH GAIN x y	Set the gain in dB for the channel assigned to output x {x=[1~5, SUB,NONE]}, {y=[-12~12]}
SET OUT CH DISTANCE x y z	"Set the distance y (in units z) between the speaker assigned to output x and the listener. Limited to one x y z entry. {x=[1~5, SUB,NONE]}, {y=[0.1~30] 0.1 step, z=[FEET]; y=[0.03~9] 0.01 step, z=[METERS]}"
SET OUT FREQ RESPONSE x y	"Set output x frequency response y {x=[1&2, 3, 4&5, ALL], y=[XOVER,FULLRANGE]} 1&2=OUTPUT 1 (L) and OUTPUT 2 (R), 3=OUTPUT 3, 4&5=OUTPUT 4 (L) and OUTPUT 5 (R) "
SET XOVER FREQ x	Set cross over cutoff frequency y for channel(s) x in increments of 5 {x=[40~120]}
GET OUT CH	" Get channel/channel pairs assigned to output(s) 1_2, 3, 4_5, SUB in order SUR=SURROUND, TM=TOP MIDDLE, FH=FRONT HEIGHT, DE=DOLBY ENABLED, HP=HEADPHONE, SUB=SUBWOOFER 1_2=OUTPUT 1 (L) and OUTPUT 2 (R), 3=OUTPUT 3, 4_5=OUTPUT 4 (L) and OUTPUT 5 (R) "
GET OUT CH GAIN x y	Get the gain in dB for the channel assigned to output x {x=[1~5, SUB, ALL], y=[-12~12]}

GET OUT CH DISTANCE x	" Get the distance with units between the speaker assigned to output x and the listener. {x=[1~5, SUB, ALL]}\n"
GET OUT FREQ RESPONSE x y	" Get output x frequency response y {x=[1&2, 3, 4&5, ALL]}\n1&2=OUTPUT 1 (L) and OUTPUT 2 (R), 3=OUTPUT 3,\n4&5=OUTPUT 4 (L) and OUTPUT 5 (R) "
GET XOVER FREQ x	Get cross over cutoff frequency y for channel(s) x in increments of 5 {x=[40~120]}
Network Setup Commands (xxx=[000-255], zzzz = [0001~9999])	
SET RIP xxx.xxx.xxx.xxx	Set route IP address to xxx.xxx.xxx.xxx
SET HIP xxx.xxx.xxx.xxx	Set host IP address to xxx.xxx.xxx.xxx
SET NMK xxx.xxx.xxx.xxx	Set net mask to xxx.xxx.xxx.xxx
SET TIP zzzz	Set TCP/IP port to zzzz
SET DHCP x	Set DHCP {x=[ON,OFF]}
SET HOSTNAME	Set device hostname x {x=[hostname]}
GET RIP	Get route IP Address
GET HIP	Get host IP Address
GET NMK	Get net mask
SET PDNS xxx.xxx.xxx.xxx	Set primary DNS server xxx.xxx.xxx.xxx
SET SDNS xxx.xxx.xxx.xxx	Set secondary DNS server xxx.xxx.xxx.xxx
GET TIP	Get TCP/IP port
GET DHCP	Get DHCP status
GET MAC	Get MAC address
GET HOSTNAME	Get product hostname

Related Products

Rialto 400

ACP-RIALTO400

- 2 channel, 100W amplifier
- Great way to utilize the Bijou preamp outs



RS500

ACP-RS500

- Great subwoofer amp to pair with the Bijou
- 500W output



AudioControl Dante Encoder

ACP-DANTE-E-POE

- Input audio using Digital or Analog inputs, and transmit over Dante to the Bijou5100D.



AudioControl Dante Decoder

ACP-DANTE-D-POE

- Receives audio from the Dante network to output to another device in the system.



Service

What to do if you need service

If the unit needs service, then please contact AudioControl, either by e-mail or phone. We will verify if there is anything wrong in the system that you can correct yourself, or if it needs to be sent back to our factory.

Please include the following items when returning the unit:

1. A copy of your proof of purchase. No originals please. We cannot guarantee returning them to you.
2. A brief explanation of the trouble you are having with the unit. (You'd be surprised how many people forget this.) If you can supply a really detailed description of the problem, this would be so much better, and our service technicians may add you to their Christmas Card list. Please include any notes about the system and other components you are using. Is it an intermittent problem that only occurs on the first full moon of Spring?
3. A return street address. (No PO Boxes, please).
4. A daytime phone number in case our technicians have a question about the problem you are having, or if they are just feeling lonely.
5. Package the unit in the original packaging if you still have it. Use great care and plenty of good packing materials to protect the unit and prevent it from moving about inside the box. Do not use loose materials like packing peanuts or real peanuts.

You are responsible for the freight charges to us, but we'll pay the return freight back as long as the unit is under warranty. We match whatever shipping method you use to send it to us, so if you return the unit overnight freight, we send it back overnight. We recommend United Parcel Service (UPS) for most shipments.

Please do not return the unit to AudioControl if you have not received an RMA number from our masterful customer support team.

Phone 425-775-8461

techsupport@audiocontrolpro.com

support.audiocontrolpro.com

www.audiocontrolpro.com/contact-us

Warranty

In just the same way as being covered in honey and thrown into a dark pit full of hungry woodchucks, people are scared of warranties. Lots of fine print. Months of waiting around. Well, fear no more. This warranty is designed to make you rave about AudioControl. It's a warranty that looks out for you and your client, plus helps you resist the temptation to have your friend Sparky, who's "good with electronics," try to repair your AudioControl product. So go ahead, grab a cup of tea, and carefully read through this warranty.

Our warranty has conditional conditions! "Conditional" doesn't mean anything ominous. The Federal Trade Commission tells all manufacturers to use the term to indicate that certain conditions have to be met before they'll honor the warranty. If you meet all of these conditions, AudioControl will, at its discretion, perform warranty service on any AudioControl products that exhibit defects in materials and/or workmanship during the warranty on your product for five (5) years from the date you bought it, and we will fix or replace it, at our option, during that time.

Here are the conditional conditions:

1. You need to hold on to your sales receipt! All warranty service requires original sales receipt documentation. The warranty only applies to the original purchaser from an authorized AudioControl dealer. Note: Products purchased from unauthorized dealers are not covered under warranty.
2. If an authorized AudioControl dealer installs your AudioControl product, the warranty is five years, otherwise the warranty is limited to one year.
3. Our warranty covers AudioControl products that have been installed according to the instructions in the installation manual.
4. You cannot let anybody who isn't: (A) the AudioControl factory; or (B) somebody authorized in writing by AudioControl service your AudioControl product. If anyone other than (A), or (B) messes with your AudioControl product, the warranty is void.
5. The warranty is void if the serial number is altered, defaced or removed, or if your product has been used improperly. Now that may sound like a big loophole, but here is what we mean by this: Unwarranted abuse is: (A) physical damage (don't use your product to level your dining room table); (B) improper connections (120 volts into the RCA jacks can fry the poor thing); (C) sadistic things! This is the best product we know how to build, but for example if you mount it to the front bumper of your car, drop it over the Niagara Falls or use it for Clay Pigeon shooting practice, something will go wrong.

Assuming you conform to 1 through 5, and it really isn't all that hard to do, we will have you send your product to us for warranty service.

Legalese Section

This is the only warranty issued by AudioControl. This warranty gives you specific legal rights, and you may also have rights that vary from state to state. Promises of how well your AudioControl product will work are not implied by this warranty. Other than what we've said we'll do in this warranty, we have no obligation, express or implied. We make no warranty of merchantability or fitness for any particular purpose. Also neither we nor anyone else who has been involved in the development or manufacture of the unit will have any liability of any incidental, consequential, special or punitive damages, including but not limited to any lost profits or damage to other parts of your system by hooking up to the unit (whether the claim is one for breach of warranty, negligence of other tort, or any other kind of claim). Some states do not allow limitations of consequential damages.

Acknowledgments

 **Dolby Atmos**
Dolby, Dolby Atmos, and the double-D symbol are registered trademarks of Dolby Laboratories Licensing Corporation. Manufactured under license from Dolby Laboratories. Confidential unpublished works. Copyright © 2012-2024 Dolby Laboratories. All rights reserved.

 **DTS® Digital Surround™**
FOR DTS PATENTS, SEE [HTTP://XPERI.COM/DTS-PATENTS/](http://xperi.com/dts-patents/).
MANUFACTURED UNDER LICENSE FROM DTS, INC. AND ITS AFFILIATES.
DTS, THE DTS LOGO, AND DIGITAL SURROUND ARE REGISTERED TRADEMARKS OR TRADEMARKS OF DTS, INC. AND ITS AFFILIATES IN THE UNITED STATES AND/OR OTHER COUNTRIES. © DTS, INC. AND ITS AFFILIATES. ALL RIGHTS RESERVED.

 **HDMI**
HDMI, the HDMI logo and High-Definition Multimedia Interface are trademarks or registered trademarks of HDMI Licensing LLC.

Thank you for choosing AudioControl!
Please contact us with any questions, we are
happily at your service!

AudioControl®

an **AV** Pro  brand

22410 70th Avenue West ~ Mountlake Terrace, WA 98043

support: 425-775-8461

techsupport@audiocontrolpro.com